

TAC 41

Aluminium

user manual



TAC 41

Aluminium



TABLE OF CONTENT

SAFETY.....	4
WARNINGS.....	4
BOX CONTENT.....	5
GUN DESCRIPTION.....	5
STOCK HINGE OPERATION.....	6
SAFETY OPERATION.....	7
MAGAZINE OPERATION.....	7
FEEDING RAMP INITIALIZATION.....	8
SHOOTING OPERATION.....	8
FEEDING RAMP RESET.....	9
HOPUP ADJUSTMENT.....	10
ADVANCED SETTINGS & ERGONOMICS.....	11
EXPLODED VIEWS.....	12
MATERIALS/MASS/SIZE/CAPACITY.....	13
DIGITAL VERSION.....	14



TMC

SAFETY

READ THIS MANUAL CAREFULLY AND THOROUGHLY BEFORE USE, users should obey to laws regarding the usage and ownership of airsoft guns in their country. Misuse or careless use may cause serious injuries. Always treat airsoft guns as if they are loaded and with the same respect as you would treat firearms. Do not look into an airsoft gun muzzle. Never point the airsoft gun at something you do not intend to shoot. Users should always wear safety glasses. Always carry the airsoft gun in a bag or a case and never display it in public places. Always keep the airsoft gun in "safe" mode until you are ready to shoot at a safe direction. Always check that the airsoft gun is in "safe" mode and unloaded when getting it from another person or from storage. Do not put the airsoft gun away or in storage while it is still loaded. Do not shoot at hard surfaces or water surfaces as BBs could bounce or ricochet and hit someone or something you do not intend to hit. Always use high quality 6 mm plastic BBs and never use already shot BBs as it may damage your airsoft gun. Always store airsoft guns in a secure place and out of reach from children. Do not attempt to modify or alter your airsoft guns, as doing so may make your airsoft gun unsafe to use and/or cause serious injuries and/or void the warranty. **WE ARE NOT RESPONSIBLE FOR ANY MALFUNCTIONS, ACCIDENTS, INJURIES OR REPAIR COSTS RESULTING FROM MISUSE, DISASSEMBLY AND/OR MODIFICATION OF THIS AIRSOFT GUN.**



WARNINGS

- The feeding ramp can hold 20 BBs, that means the Tac-41 is able to shoot without a magazine.
- Do not pull the trigger while the bolt is not locked or you will damage the receiver.
- If you remove the magazine while it's not empty, you will lose 2 bbs. To avoid losing any bbs, remove the magazine only when it's empty.
- To avoid miss-feed, do not hold the gun by the magazine while reloading the gun.
- Do not loosen the 3 barrel screws too much while changing the barrel or you will deform the stock panel.
- In case of inner barrel disassembly, do not overtighten the lateral screws or you will damage the inner barrel.
- It is almost impossible to remove the hopup rubber without tearing it: do not attempt to disassemble the hopup rubber if you are not going to replace it.
- Using the trigger adjustments at maximum will generate safety problems and slamfire problems.
- Do not overload the magazine or you may damage the magazine.
- Maximum torque for the 3 barrel screws is 4 Nm.
- For storage, empty the feeding ramp and keep the steel parts greasy to avoid rusting.
- Do not apply any grease/oil inside the hopup and/or the barrel.
- Keep the bolt closed during barrel changes to ensure perfect bolt and barrel alignment.
- Make sure no BBs remain in the hopup and the feeding ramp before removing the barrel.



BOX CONTENT

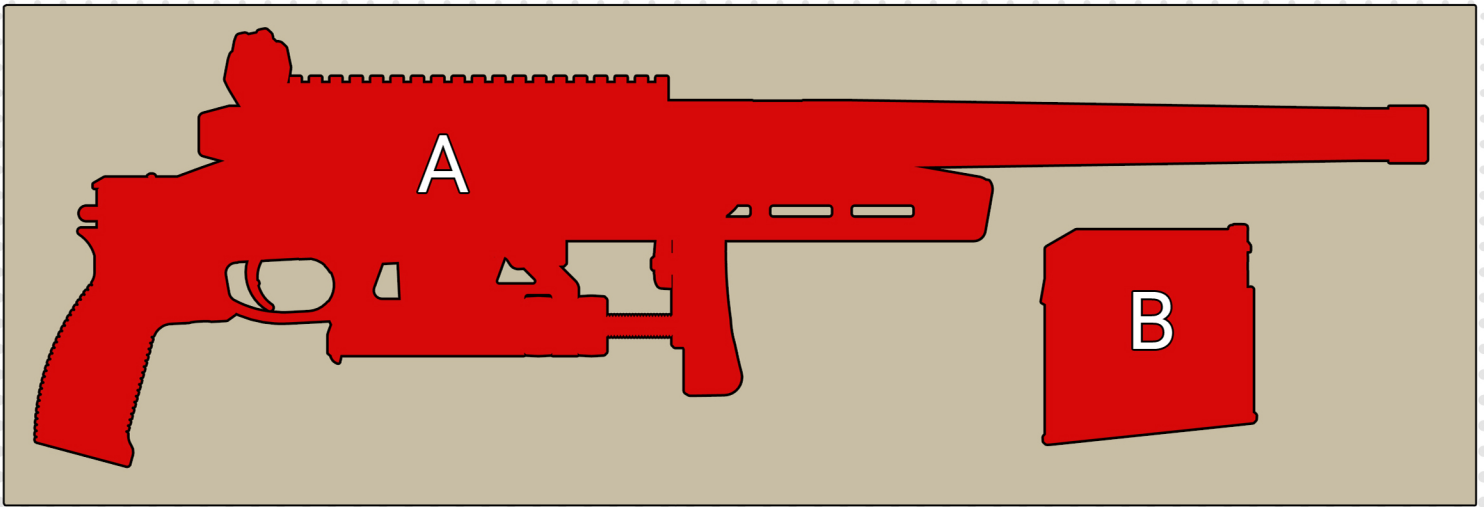

A: TAC-41 A (folded stock)
B: Long magazine

GUN DESCRIPTION

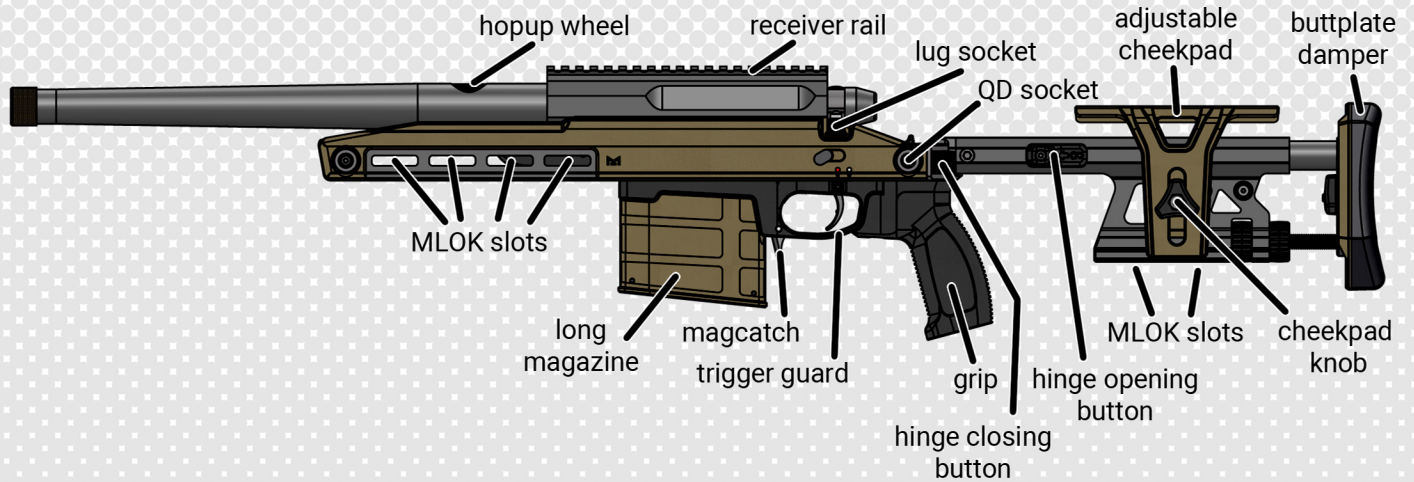

STOCK HINGE OPERATION



OPENING PROCEDURE: start by lifting the bolt handle.

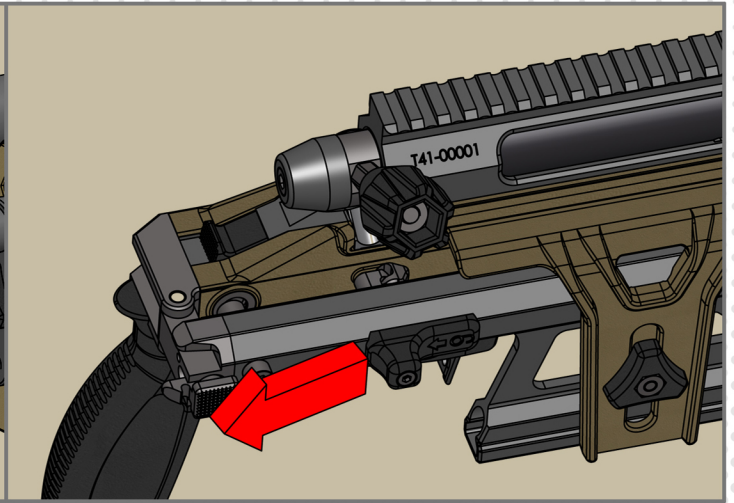

Pull back the release button.

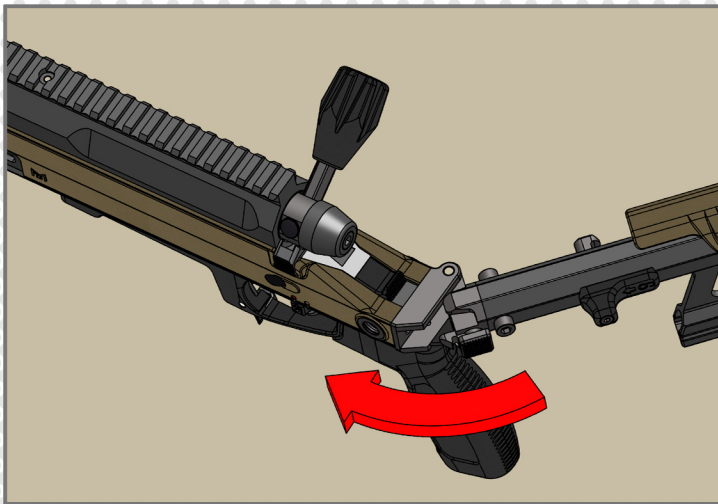

Open the stock firmly until the locking system engages (it must "click").

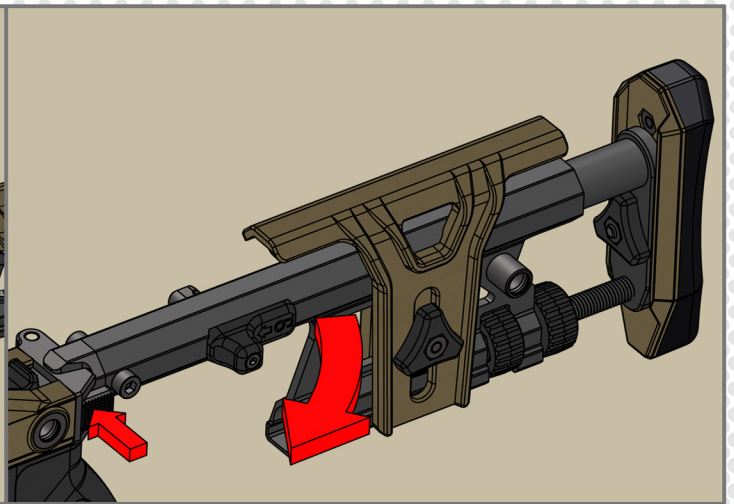

CLOSING PROCEDURE: while exerting effort in the direction of the stock opening, press the stock opening button.

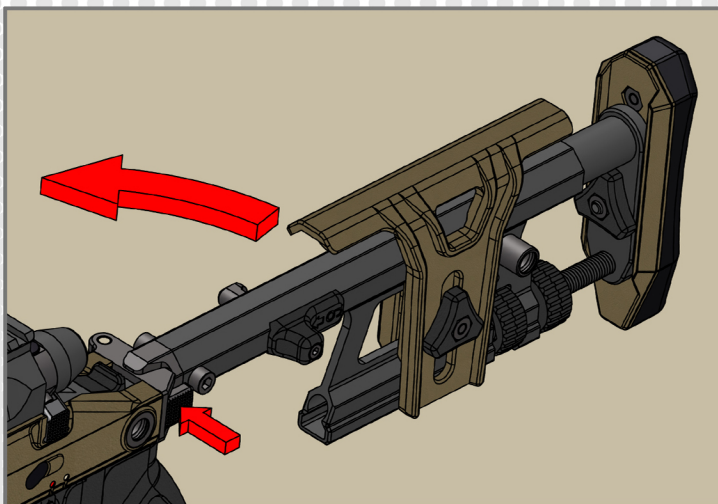

While pressing the release button, fold the stock.

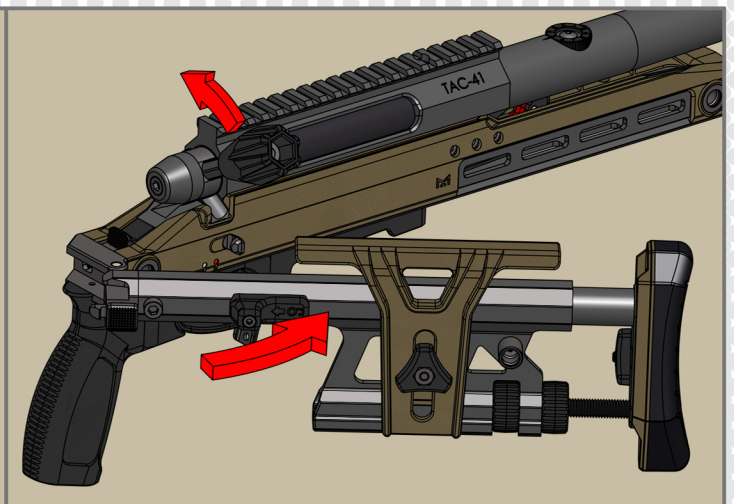

Make sure the bolt handle is up, and firmly close the stock until it locks in the open position (it must "click").

SAFETY OPERATION

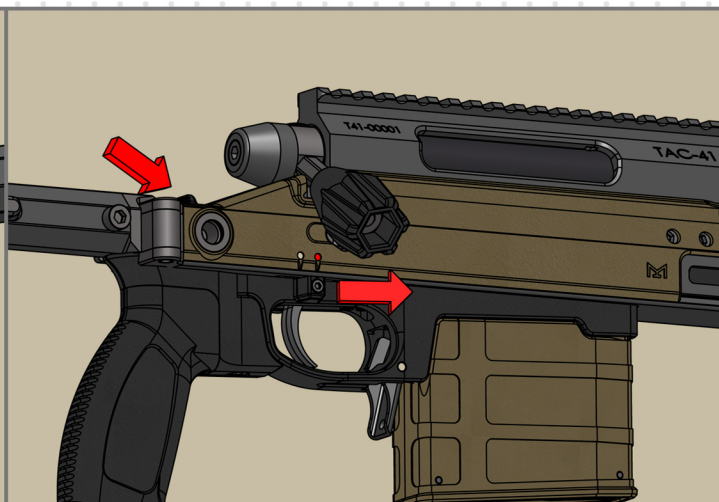

Slide the safety button (right OR left OR central) towards the back to engage safety. The lateral button must be under the white dot. Safety engagement may be firm when the rifle is new.

Slide the safety button (right OR left OR central) towards the front to disengage the safety. The lateral button must be under the red dot.

MAGAZINE OPERATION

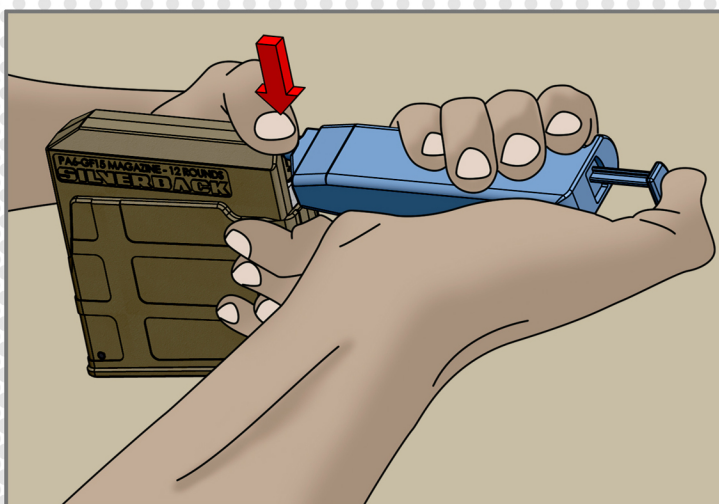

Fill the magazine with 6 mm bbs, preferably using a BB-loader. You will need to press on the magazine gate (as shown) to load the magazine. Magazine capacity: 110 bbs.

Insert the magazine as shown.

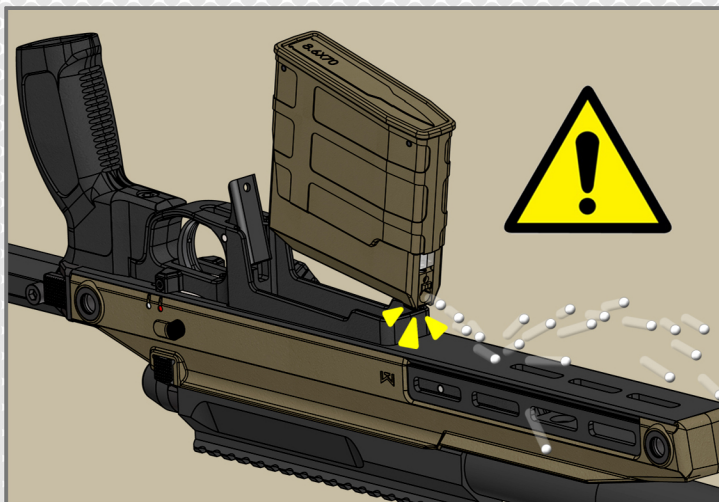

When engaging the magazine, be careful not to hit the mag gate on to the trigger guard, or else all the bbs will burst out of the magazine.



To disengage the magazine, push forward the magcatch and let the magazine drop by gravity.

FEEDING RAMP INITIALIZATION



Engage a loaded magazine to pre-fill the feeding ramp (20 bbs are required).

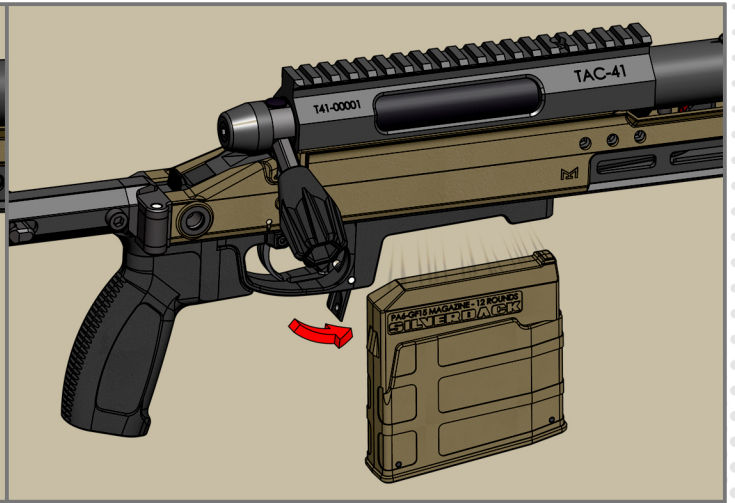

Disengage the magazine.

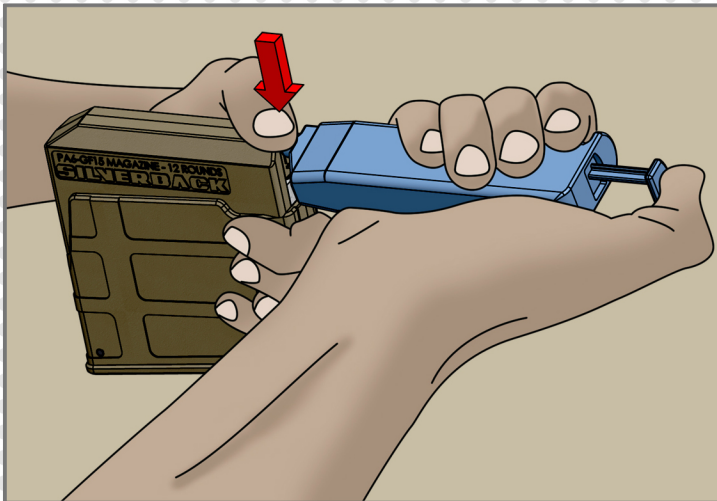

Refill the magazine (110 bbs maximum).



Re-engage the magazine. Your TAC-41 is now ready to shoot.

SHOOTING OPERATION



Lift up the bolt handle (make sure the bolt is not already loaded to avoid double feeding).



Pull the bolt backwards to compress the spring and lock the piston sear (until it clicks).



Make sure not to pull the trigger by accident when the bolt is pulled back.

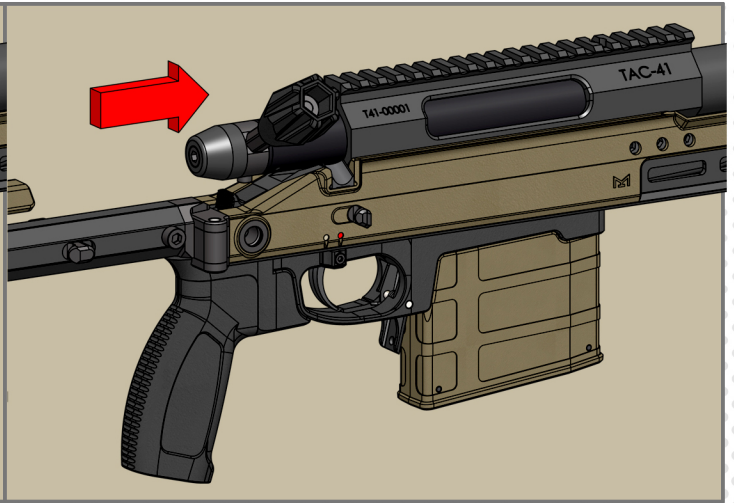

Push the bolt forward to engage a BB inside the hopup. **WARNING:** while loading the BB inside the hopup, do not hold the gun by the magazine to avoid miss-feed.



Lower the bolt handle to lock the bolt.

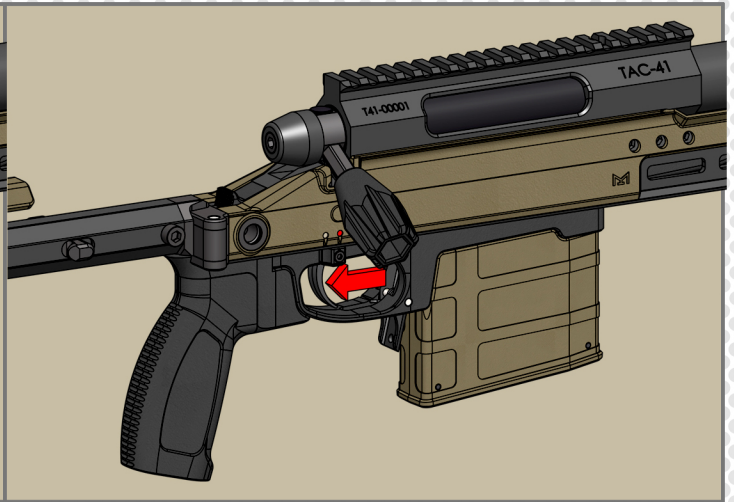

Pull the trigger to shoot. (Make sure that the safety is disengaged).

FEEDING RAMP RESET

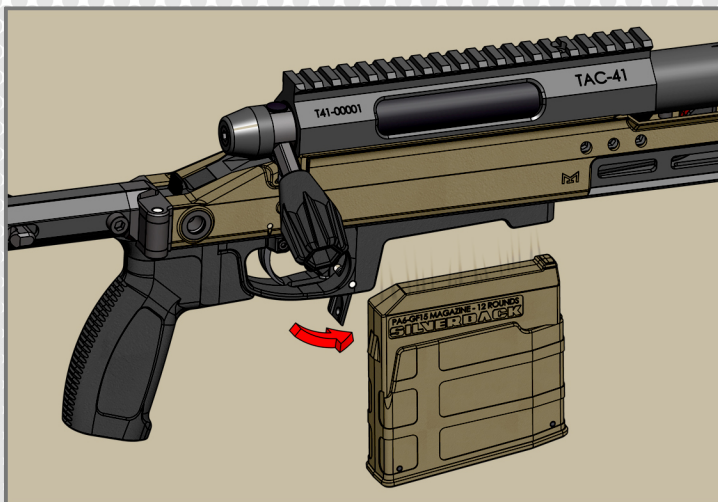

Disengage the magazine.

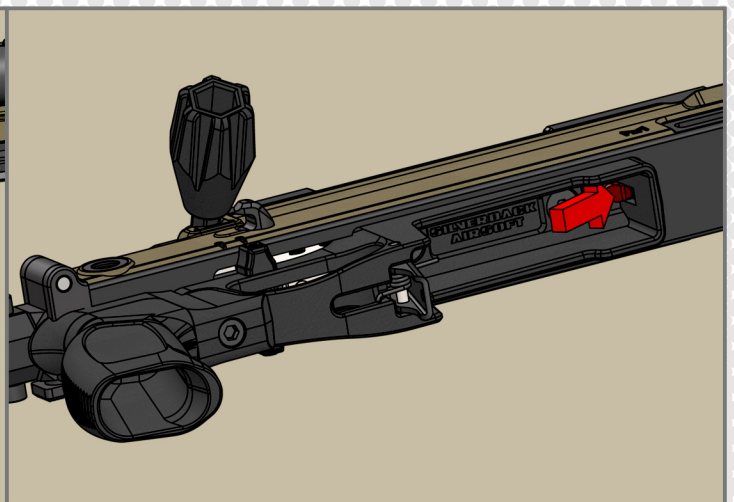

Press the feeding ramp stopper to release all the BBs inside the feeding ramp by gravity (tilt the gun at an angle with the muzzle facing upward and the trigger guard facing downward).

HOPUP ADJUSTMENT

Each «click» is increasing/decreasing the hopup preload by 15 μm . There are 50 positions for the hopup wheel, ranging from 0 up to 750 μm .

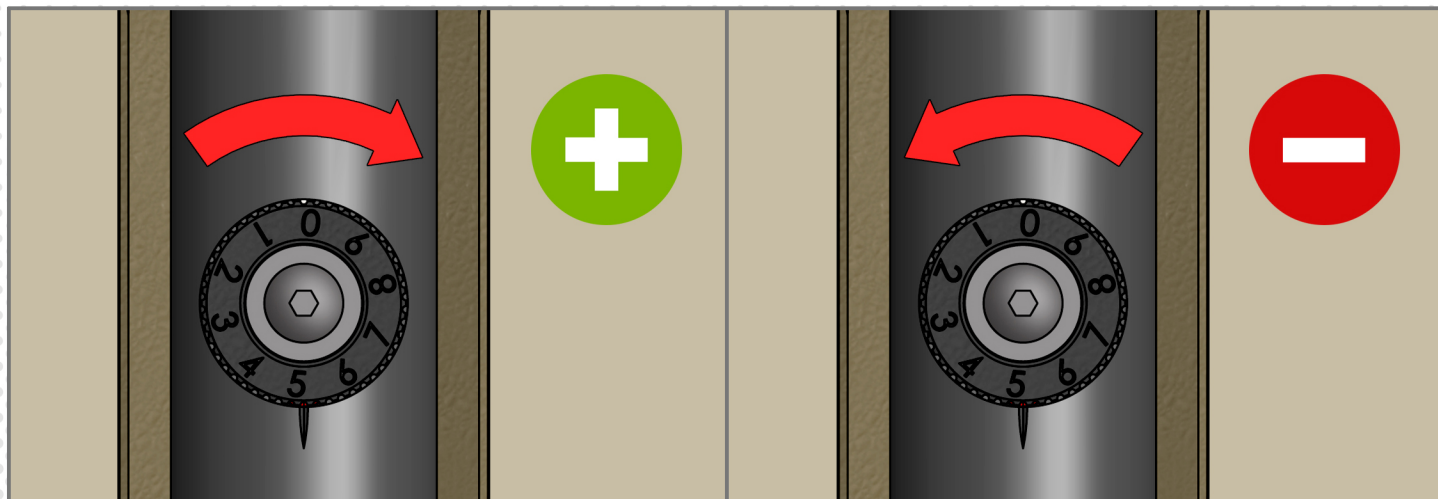

Turn the Hopup in clockwise direction to increase hopup effect.

Turn the Hopup in counterclockwise direction to reduce hopup effect.

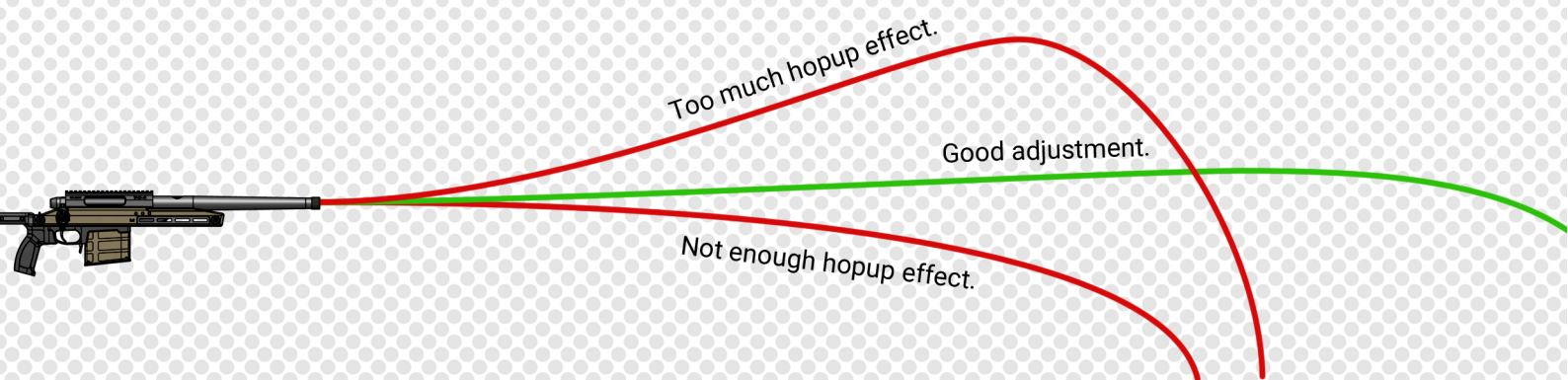

WARNINGS

- Hopup adjustment needs to be done every time you change the BBs mass or the muzzle energy.
- Excessive hopup adjustment will jam the gun.
- In case of jam
 1. remove the magazine,
 2. turn the hopup wheel to «0»,
 3. cycle the bolt,
 4. shoot in a safe direction.
- Hopup adjustment may affect your muzzle energy: always check your muzzle energy after adjusting your hopup using in-game bbs and make sure it is within the limits of your local law/rules.
- It is mandatory to keep your hopup clean and dry to be effective.
- You can switch from the position «9» to the position «0», but you cannot do the opposite.
- To avoid any sidespin, be sure to hold your rifle straight before pulling the trigger.



ADVANCED SETTINGS & ERGONOMICS

To help you with the ergonomics and advanced settings, please check out our YouTube channel for the tutorials. Scan the QR code on this page to access our YouTube channel.

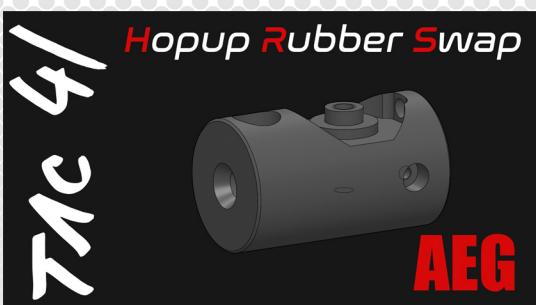
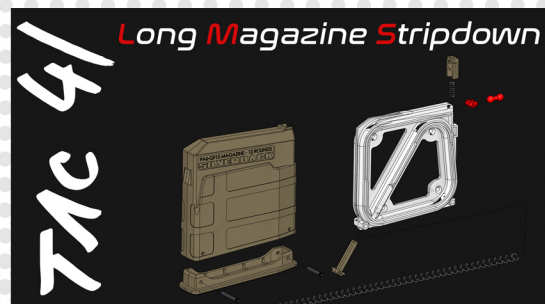
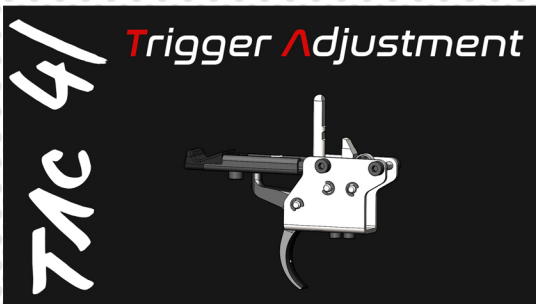



Scan this QR code to access the detailed exploded views.

EXPLODED VIEWS

T41-0100
RECEIVER

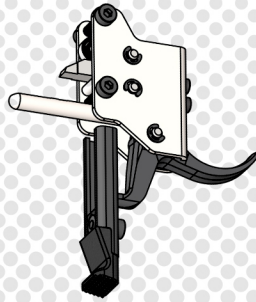
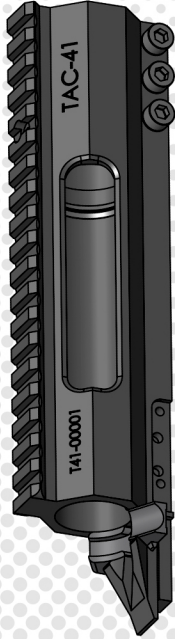

T41-0500
TRIGGER
GROUP

T41-0600
LONG
MAGAZINE

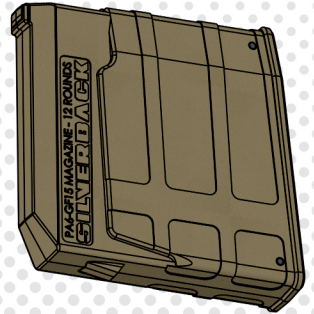

T41-1100
ALUMINIUM
FOLDABLE
CHASSIS

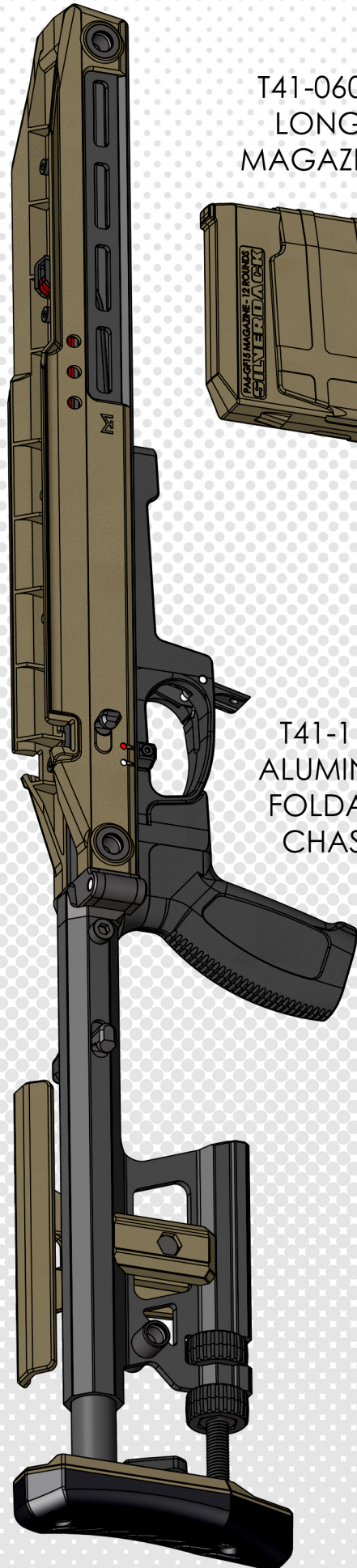

T41-0200-06
330 MM BARREL

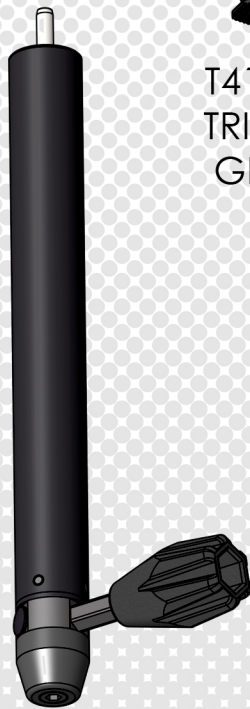

T41-0300
BOLT

MATERIALS / MASS / SIZE / CAPACITY

	Receiver	Outer Barrel	Inner Barrel	Hopup	Bolt	Polymer Stock	Aluminium Chassis	Cheekpad	Buttplate	Trigger Box	Spring Guide Stopper	Safety	Trigger Guard	Magcatch	BB Feeding Ramp	Magazines	Screws	O-rings
Aluminium 6000 Series	■	■	■	■	■	■	■	■	■	■	■	■	■	■	■	■	■	■
Aluminium ADC-12	■	■	■	■	■	■	■	■	■	■	■	■	■	■	■	■	■	■
Steel CR1018	■	■	■	■	■	■	■	■	■	■	■	■	■	■	■	■	■	■
Stainless Steel SS304	■	■	■	■	■	■	■	■	■	■	■	■	■	■	■	■	■	■
Steel 10.9	■	■	■	■	■	■	■	■	■	■	■	■	■	■	■	■	■	■
Brass	■	■	■	■	■	■	■	■	■	■	■	■	■	■	■	■	■	■
Nylon PA6-GF15	■	■	■	■	■	■	■	■	■	■	■	■	■	■	■	■	■	■
ABS	■	■	■	■	■	■	■	■	■	■	■	■	■	■	■	■	■	■
PC	■	■	■	■	■	■	■	■	■	■	■	■	■	■	■	■	■	■
NBR	■	■	■	■	■	■	■	■	■	■	■	■	■	■	■	■	■	■
Silicon 60°	■	■	■	■	■	■	■	■	■	■	■	■	■	■	■	■	■	■

CATEGORY #	CATEGORY NAME	[gram]
T41-0100	RECEIVER	349
T41-0200-02	BARREL 510 mm	486
T41-0200-06	BARREL 330 mm	362
T41-0300	BOLT	474
T41-0400	POLYMER STOCK w/o T41-0700	1191
T41-0500	TRIGGER GROUP	126
T41-0600	LONG MAGAZINE	139
T41-0700	TRIGGER GUARD	116
T41-1000	SHORT MAGAZINE	79
T41-1100	ALUMINIUM FOLDABLE CHASSIS w/ T41-0700	1391
TAC-41 A	TOTAL	2841
TAC-41 P	TOTAL	2821

Mass tolerances: +/- 0.2 %

SIZE	[mm]
T41-P minimum size:	1095
T41-P maximum size with 6 buttplate spacers (3 pcs. included):	1155
T41-P inner barrel (AEG type) length:	510
T41-A folded size:	682
T41-A minimum unfolded size:	922
T41-A maximum unfolded size:	1022
T41-A inner barrel (AEG type) length:	330

Size tolerance: +/- 0.2 %

CAPACITY	[bbs]
Short magazine	48
Long magazine	110
Feeding ramp	20

DIGITAL VERSIONS

You can download the PDF version of this manual in different languages by scanning the QR codes below. If the manual is updated, these links will direct you to the latest versions. If you would like to contact us about your TAC-41, or if you would like to receive news on this product line, please contact us at info@silverback-airsoft.com with your serial number as a reference.

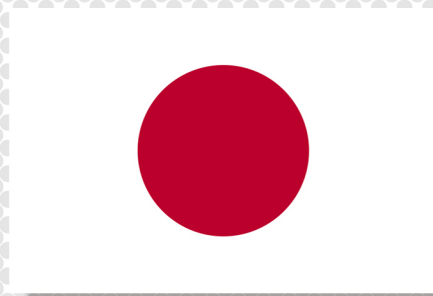
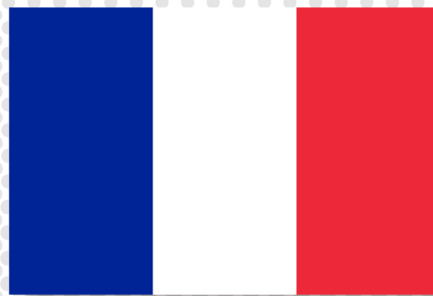

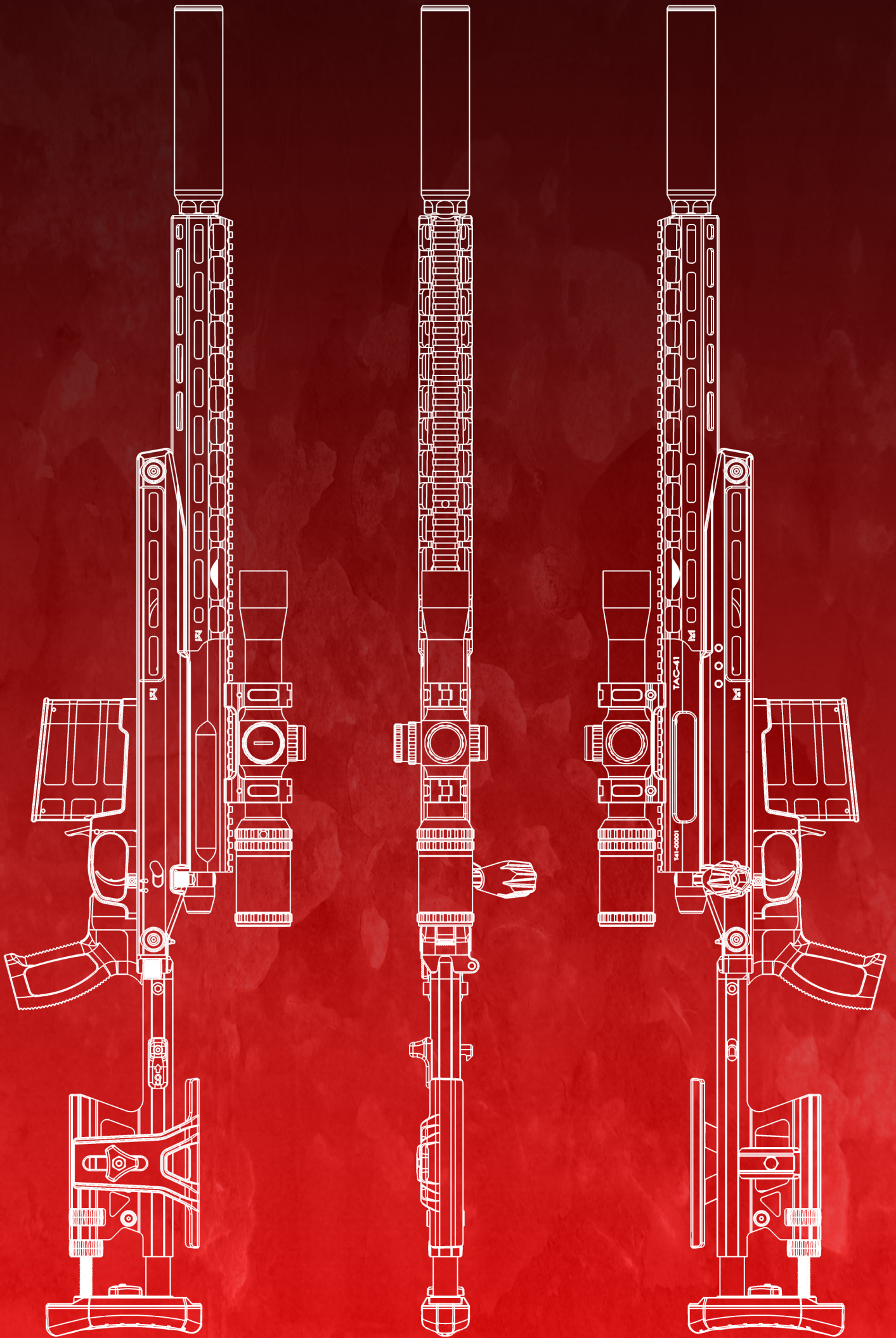



April 2022 - Made in China

SILNERBACK AIRSOFT